

Directional valve 3-way/2-position

$Q_{\max} = 10 \text{ gpm}$, $p_{\max} = 4500 \text{ psi}$
switching solenoid, direct acting, poppet type
Type series: W1N32G-8-AU



- Screw-in cartridge valve
- For cavity AU/C1030
- All external parts with zinc-nickel plating according to DIN EN ISO 19598
- Guided valve spool and poppet
- With or without manual override
- Low head loss
- High flow rates
- The slip-on coil can be rotated, and it can be replaced without opening the hydraulic envelope
- High pressure wet-armature solenoids
- Various plug-connector systems and voltages are available

Description

The 3-way/2-position solenoid operated directional seat valves, series W1N..., are size NG8 / SAE 10, direct acting, pressure balanced, screw-in valves with a 7/8-14 UNF mounting thread. They are designed on the poppet/seat principle and in the normal condition (de-energized), flow in port 3 is shut off without leakage. The guide spool has a seal. This version is the underlapped spool model. See separate data sheet for the overlapped spool model. These valves are also available with or without manual override. All external parts of the screw-in valves are zinc-nickel plated and

are thus suitable for use in the harshest operating environments. The slip-on coils can be replaced without opening the hydraulic envelope and can be positioned at any angle through 360°. These valves are predominantly used in certain mobile and industrial applications where leak-tight shut-off functions are crucially important. Examples are where loads, tensions, or clamping forces must be held without leakage. For self-assembly, please refer to the section related data sheets.

Symbol

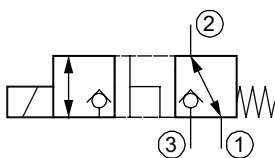

Technical data

General characteristics	Description, value, unit
Function group	Directional valve
Function	3-way/2-position
Design	Screw-in cartridge valve
Controls	switching solenoid
Characteristic	direct acting, poppet type
Construction size	NG 8 / SAE 10
Thread size	7/8-14 UNF-2A
Mounting attitude	unrestricted
Weight	1.5 lbs
Cavity acc. factory standard	For cavity AU/C1030
Tightening torque steel	44 ft·lb
Tightening torque aluminium	44 ft·lb
Tightening torque tolerance	± 10 %
Minimum ambient temperature	- 13 °F
Maximum ambient temperature	+ 122 °F
Surface protection	All external parts with zinc-nickel plating according to DIN EN ISO 19598
Sealing material	see ordering code
Seal kit order number	NBR: DS-507-N / FKM: DS-507-V



IMPORTANT!

The less favorable values from the general, hydraulic and electrical characteristics determine the temperature range of the whole valve.

Hydraulic characteristics	Description, value, unit
Maximum operating pressure	4500 psi
Maximum flow rate	10 gpm
Flow direction	see symbol
Hydraulic fluid	HL and HLP mineral oil according to DIN 51 524; other fluids on request!
Minimum fluid temperature	- 13 °F
Maximum fluid temperature	+ 176 °F
Viscosity range	10 ... 500 mm ² /s (cSt)
Recommended viscosity range	15 ... 250 mm ² /s (cSt)
Minimum fluid cleanliness (cleanliness class according to ISO 4406:1999)	class 20/18/15

Electric characteristics	Description, value, unit
Actuator type	solenoid coil
Solenoid coils type	D45/207
Supply voltage DC	12/24 V DC
Supply voltage AC	115/230 (50 ... 60 Hz) V AC
Supply voltage tolerance	± 10 %
Maximum permissible power consumption	30 ... 32 W
Switching time	Flow direction 3 to 2: 17 ... 109 (energizing), 7 ... 198 (de-energizing) / Flow direction 1 to 2: 22 ... 150 (energizing), 6 ... 60 (de-energizing) / Flow direction 2 to 1: 23 ... 117 (energizing), 10 ... 72 (de-energizing) / Flow direction 2 to 3: 25 ... 138 (energizing), 7 ... 10 (de-energizing)
Relative duty cycle	100 %
Electrical connection coil	DIN EN 175301-803, 3-pole 2 P+E (IP 65)
Protection class solenoid coil to ISO 20 653 / EN 60 529	IP 65 / IP 67 / IP 69K, see "Ordering code" (with appropriate mating connector and proper fitting and sealing)

i NOTE!
To ensure the performance data is not compromised, it is imperative to use coils D45/207 according to data sheet 400-P-120120.

i NOTE!
These times are strongly influenced by fluid pressure, flow rate and viscosity, as well as by the dwell time under pressure.

Performance graphs

measured with oil viscosity 33.0 mm²/s (cSt), coil at steady-state temperature and 10 % undervoltage

$p = f(Q)$ Performance limit

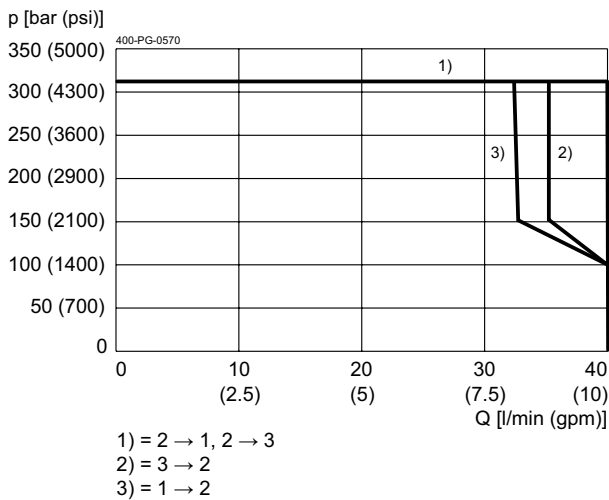

$\Delta p = f(Q)$ Pressure drop-flow rate characteristic

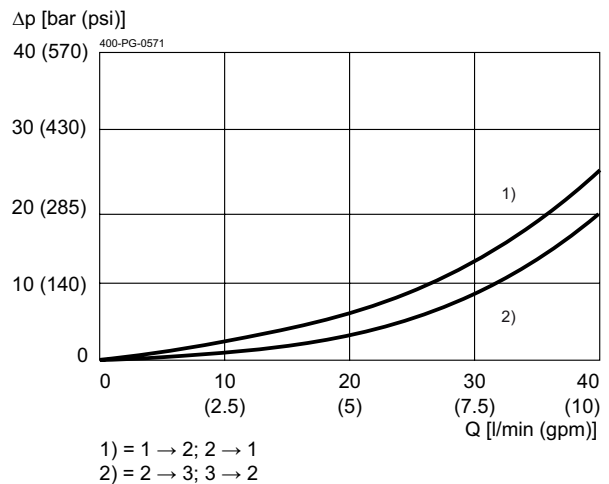

Dimensions and sectional view

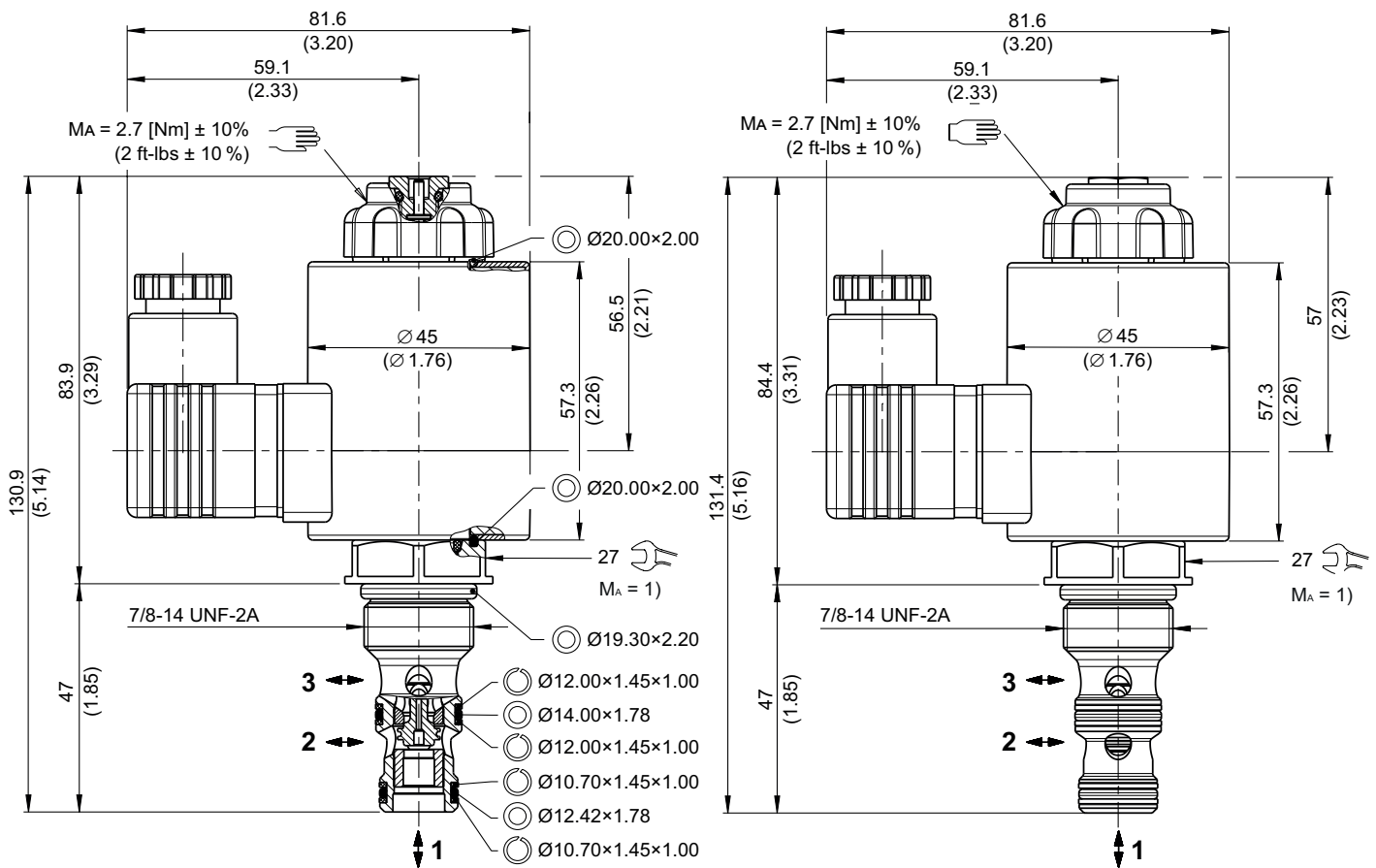

Installation information



NOTE!

1) When fitting the screw-in cartridge valve, use the specified tightening torque. The value can be found in the chapter "Technical data".



ATTENTION!

Only qualified personnel with mechanical skills may carry out any maintenance work. Generally, the only work that should ever be undertaken is to check, and possibly replace, the seals. When changing seals, oil or grease the new seals thoroughly before fitting them.

Functional principle / Spool variants

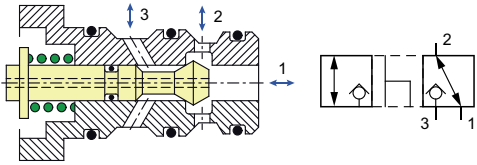

Ordering code

Ex.

W1	N	32	G	I	U	A	-	8	O	-	1	24	D	-	-
----	---	----	---	---	---	---	---	---	---	---	---	----	---	---	---

- W1 = directional valve
 - N = negative overlap
 - 32 = 3-way/2-position
 - G = spool de-energized closed
 - I = electrically operated, D45/207, 30...32W
 - U = cavity AU/C1030
 - A ... Q = standard model - see relevant data sheets
 - R ... Z = special features - please consult BUCHER
 - 8 = nominal size 8
 - O = without override (**standard**)
 - P = push override
 - (blank) = NBR (Nitrile) seals (**standard**)
 - V = FKM (Viton) seals
(special seals - please contact BUCHER)
 - 1 ... 9 = design stage (omit when ordering new units)
 - ... = voltage e.g. **24** (24 V)
 - D = current DC
 - A = current AC
 - (blank) = DIN EN 175301-803 connection with mating plug (**standard, IP 65**)
 - M100 = DIN EN 175301-803 connection with mating plug
- for the following plug-variants [mating plug not supplied], please consult BUCHER:*
- DT = Deutsch plug connection DT04-2P (with quenching diode, IP 67/69K)
 - JT = Junior Timer radial plug connection (with quenching diode, IP 65)
 - F = flying leads (600mm) (IP 65)

Related data sheets

Reference	Description
400-P-040011	Form tools
400-P-120120	Solenoid coil D45/207
400-P-040291	Cavity AU/C1030

info.ch@bucherhydraulics.com

www.bucherhydraulics.com

© 2023 by Bucher Hydraulics AG Frutigen, 3714 Frutigen, Switzerland

All rights reserved.

Data is provided for the purpose of product description only, and must not be construed as warranted characteristics in the legal sense. The information does not relieve users from the duty of conducting their own evaluations and tests. Because the products are subject to continual improvement, we reserve the right to amend the product specifications contained in this catalogue.